

CASTOR® V

Transport and Storage Cask
for Spent Fuel (PWR/BWR)

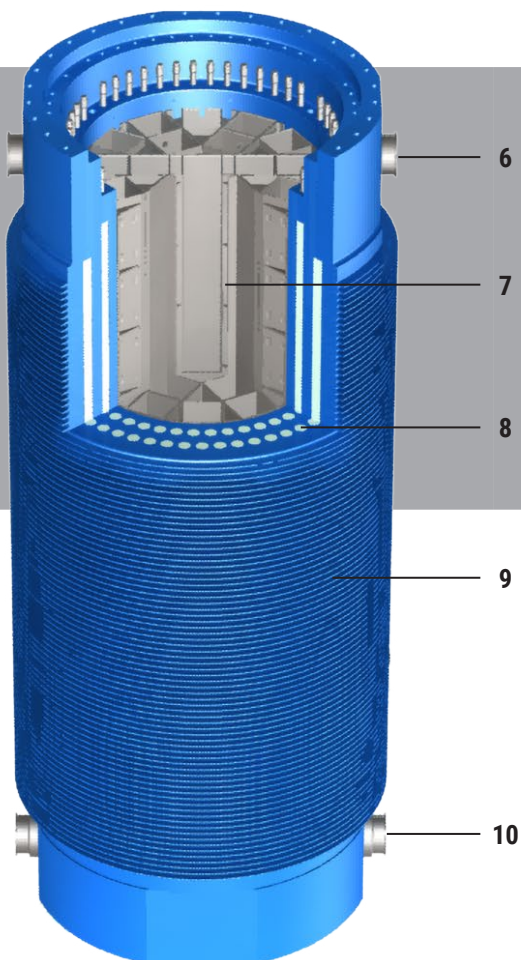
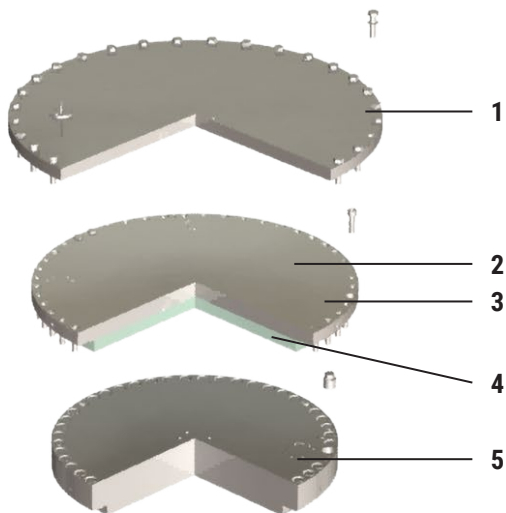

- Dual purpose cask for transport and storage of PWR/BWR fuel assemblies also in combination with spent MOX fuel
- Suitable for complete defueling of all inventory in combination with GNS IQ Quiver System
- Load & Go and Store & Go – No overpack required for transport and storage
- No risk of chloride induced stress corrosion cracking due to absence of welding seams in contrast to competing canister based concrete cask systems
- Based on over 40 years of experience and the proven design principle of the CASTOR® family

DESCRIPTION

CASTOR® V casks are designed for the transport and storage of irradiated fuel elements from pressurised water reactors (PWR/CASTOR® V/19) or boiling water reactors (BWR/CASTOR® V/52).

The cask consists of a monolithic body [9] made of ductile cast iron, a basket [7] for accommodating the fuel assemblies and a double-lid system (primary [5] and secondary lid [2] arranged one above the other) as well as a protection plate [1].

On the outside wall, radial cooling fins are machined to improve the passive heat dissipation. The double-lid system made of stainless steel is tightly bolted to the cask body guaranteeing a safe long-term containment of the fuel assemblies. During interim storage the lid system consisting of the two barriers is permanently being monitored for leak-tightness. Monitoring is performed by a pressure switch [3] which is integrated in the secondary lid.

For neutron moderation, axial boreholes are drilled into the cask wall and filled with polyethylene moderator rods [8]. In addition, there are plates of polyethylene [4] at the bottom end and on the underside of the secondary lid.

At the bottom and lid end of the cask body, one pair of trunnions [6, 10] each is bolted for attachment of handling equipment. For transport on public routes the cask can be equipped with shock absorbers.

Excellence for Nuclear.

GNS Gesellschaft für Nuklear-Service mbH · Frohnhauser Str. 67 · 45127 Essen · Germany
Phone +49 201 109-0 · gns-sales@gns.de · www.gns.de

CASTOR® V

Transport and Storage Cask
for Spent Fuel (PWR/BWR)



LICENSES

The CASTOR® V has the necessary licenses for transport, long-term interim storage as well as for handling in nuclear facilities.

The design complies with the international regulations from the IAEA (International Atomic Energy Agency) for type B(U)F package designs for the transport on public transport ways (roads, rail, shipping).

REFERENCES

Already more than 720 CASTOR® V-casks have been loaded and stored so far.

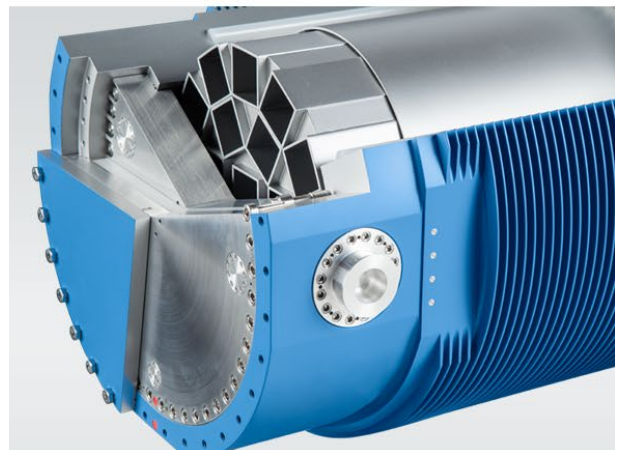

Excellence for Nuclear.

GNS Gesellschaft für Nuklear-Service mbH · Frohnhauser Str. 67 · 45127 Essen · Germany
Phone +49 201 109-0 · gns-sales@gns.de · www.gns.de