

CASTOR[®] geo with CLU System

CASK LOADING UNIT

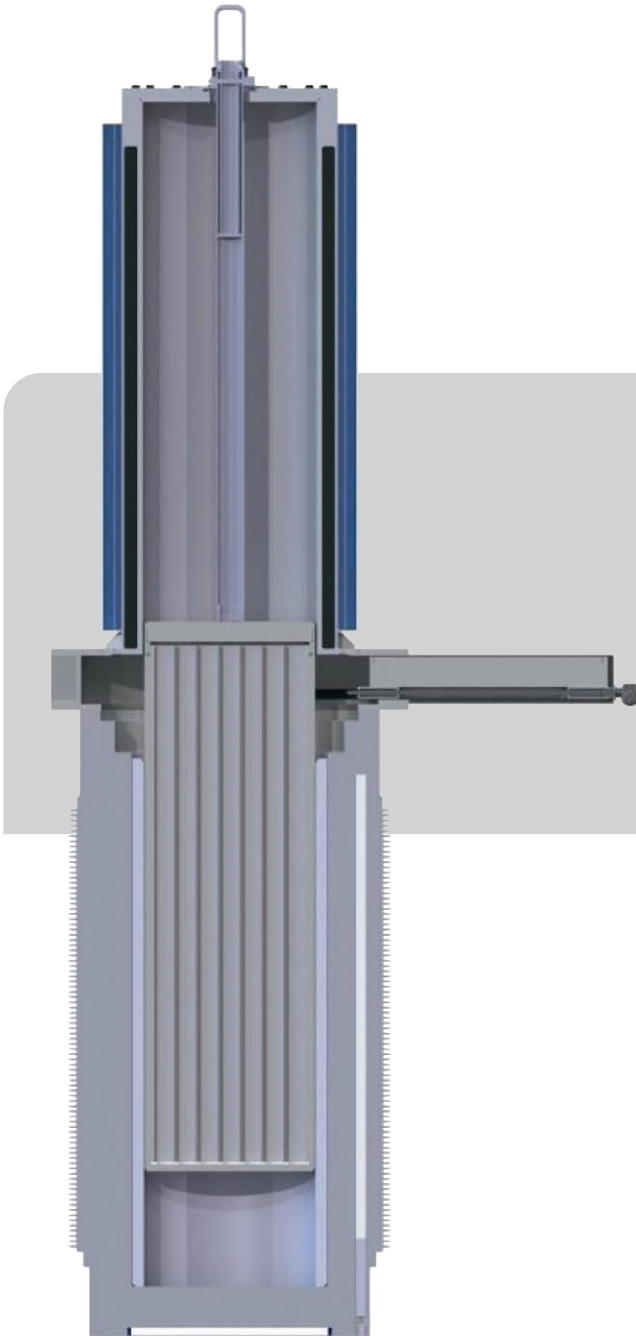

- Combines the advantages of canister systems with the highest safety of CASTOR[®] dual purpose casks
- Suitable for limited crane-lifting capacities
- Only canister system on the market with easy re-opening - Canister lid is not welded to the canister
- Easy re-opening and unloading of the canister and cask for later final disposal or fuel inspection

DESCRIPTION

- Canister based system for internal transfer increases FA capacity with given pool crane-lifting capacity due to smaller masses of CLU compared to standard cask
- Dual Purpose Cask with bolted double lid system for storage and public transport
- Smooth licensing since majority of the existing safety cases of CASTOR[®] casks is also applicable for the CLU system
- No direct venting of canister system in contrast to competing concrete cask systems, thus chloride induced stress corrosion cracking at canister weldings is technically excluded.

LICENSES

- On-going licensing for 10 CFR 71 / 10 CFR 72 with US-NRC

Excellence for Nuclear.

GNS Gesellschaft für Nuklear-Service mbH · Frohnhauser Str. 67 · 45127 Essen · Germany
Phone +49 201 109-0 · gns-sales@gns.de · www.gns.de