

# CASTOR® HAW28M

Transport and Storage Cask  
for Vitrified Waste

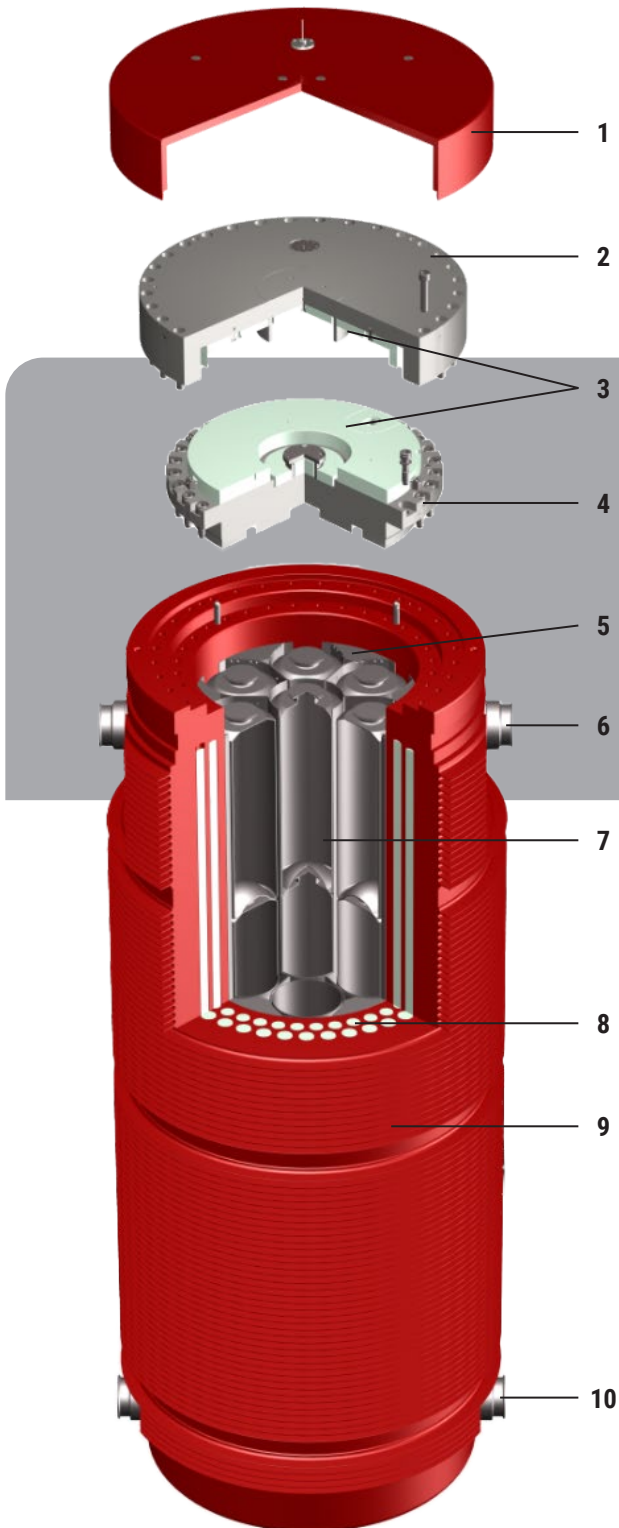

- Dual purpose cask specially designed for transport and storage of vitrified waste from reprocessing
- Fully compliant with the acceptance criteria in La Hague and Sellafield
- Based on over 40 years of experience and the proven design principle of the CASTOR® family

## DESCRIPTION

The CASTOR® HAW28M is designed for the transport and interim storage of up to 28 canisters [7] with heat-generating vitrified waste from the re-processing of spent fuel.

The cask consists of the thick-walled cylindrical cask body [9] made of ductile cast iron. For neutron moderation axial boreholes are drilled into the cask wall and filled with polyethylene moderator rods [8]. In addition, there are shielding elements in the basket [5], a moderator plate at the bottom and a multi-part moderator plate [3] on the top of the metal sealed primary lid [4]. In the storage configuration, a secondary lid [2] is tightly secured to the cask body and a protection lid [1] attached.

On the outside wall, radial cooling fins are machined to improve the heat transfer to the environment. Four trunnions are bolted for handling and fixing the cask onto the transport equipment [6, 10]. For transport on public routes the cask can be equipped with shock absorbers.

**Excellence** for Nuclear.

GNS Gesellschaft für Nuklear-Service mbH · Frohnhauser Str. 67 · 45127 Essen · Germany  
Phone +49 201 109-0 · gns-sales@gns.de · www.gns.de

# CASTOR® HAW28M

Transport and Storage Cask  
for Vitrified Waste



## LICENSES

The CASTOR® HAW28M complies with the international regulations of the IAEA for type B(U)F package designs.

The cask complies with the acceptance criteria of the reprocessing plants in La Hague (F) and Sellafield (UK) and fulfills the requirements for transport by road, rail and sea. Furthermore the cask is approved for long-term interim storage in Germany and Switzerland.

## REFERENCES

So far 21 CASTOR® HAW28M casks have been loaded in the course of return of HLW from the reprocessing plant La Hague (F) and stored in the Gorleben interim storage facility as part of the repatriation process, and six CASTOR® HAW28M casks from Sellafield are in the Biblis interim storage facility.

Further six casks are located in the Swiss interim storage facility Zwiilag.

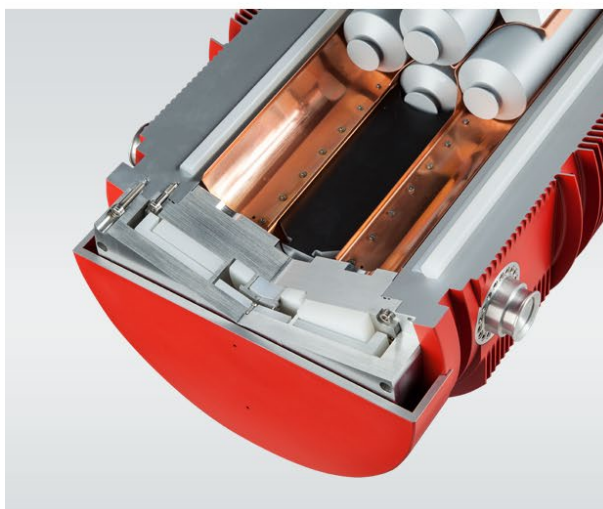

## TECHNICAL DATA

### Cask Contents

Max. 28 canisters with HLW

Total thermal power	56 kW
Total activity	1,270 PBq

### Dimensions and Weight in the Storage Configuration

Overall height	612 cm
Outer diameter	243 cm
Cavity height	518 cm
Cavity diameter	135 cm
Cask weight empty	≈ 100 t

**Excellence** for Nuclear.

GNS Gesellschaft für Nuklear-Service mbH · Frohnhauser Str. 67 · 45127 Essen · Germany  
Phone +49 201 109-0 · gns-sales@gns.de · www.gns.de